

# Green hydrogen for decarbonization

Presentation to « SEII »  
October 24, 2025



# John Cockerill Group – A leading technology partner to industrial companies



**Created in 1817**

 **>€1,4 billion** in annual turnover

 **8300+** motivated talents worldwide

 **60** nationalities

 **94+** worldwide subsidiaries, locally anchored

 **Privately held** group since 2002, with stable shareholding

**Our mission is to meet the needs of our time by operating in 5 areas of expertise**

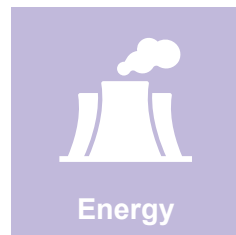

# John Cockerill Hydrogen - A leading provider of large-scale green hydrogen production solutions



## Overview



Among the leaders in Pressurized alkaline



Unparalleled experience for 100MW+ projects



Global player with multi-local presence



Partnership for innovative turnkey solutions



Hydrogen refueling solutions for mobility



Backing of strong industrial partners



## Key figures

**>600 MW / >1300** electrolyzers delivered in 30 countries

**80** stacks of 5 MW delivered since 2018 (among the largest on the market)

**>500** employees globally

**30+** years of experience in the manufacture of electrolyzers



# Electrolysis for hydrogen production is not new !

**2020s:** flexible, large-scale solutions connected to renewable resources needed

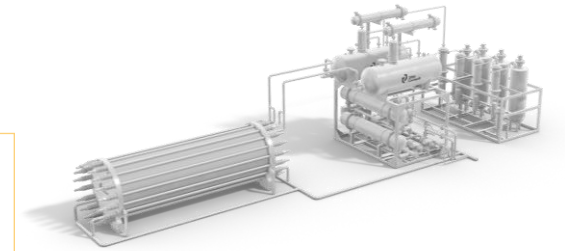

*Early development*

*Industrialization*

*Scaling up*

**1800s**

**1900s**

**2000s**

**1789:** first electrostatic generator



**1800:** hydrogen and oxygen split

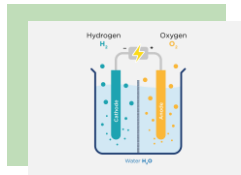

**1869:** Alkaline electrolyzer concept developed

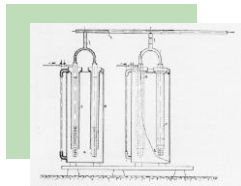

**1890:** H<sub>2</sub> production for ammonia



**1920:** MW scale Alkaline electrolyzers



**1960s:** PEM developed

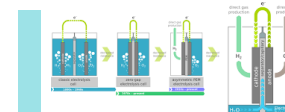

**1990s:** PEM used for mobility



# Green hydrogen production

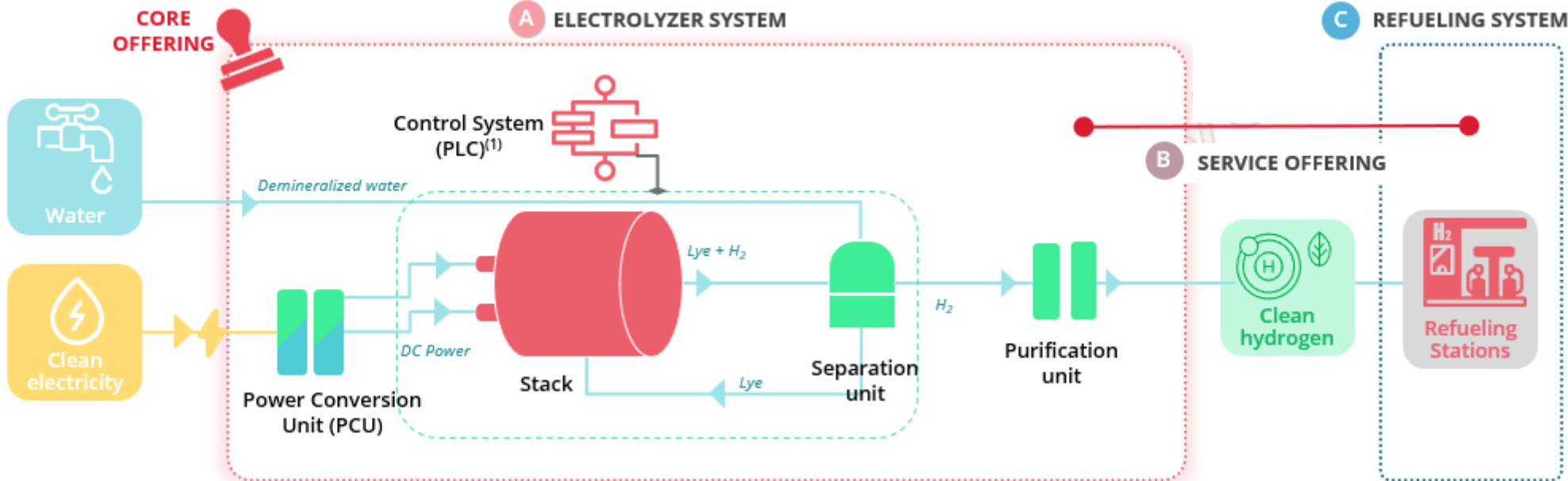

■ Components manufactured internally
 ■ Components either manufactured internally, or procured from 3<sup>rd</sup> parties
 ■ 3<sup>rd</sup> party purchased components, specified and integrated by JCH2



# John Cockerill equipments

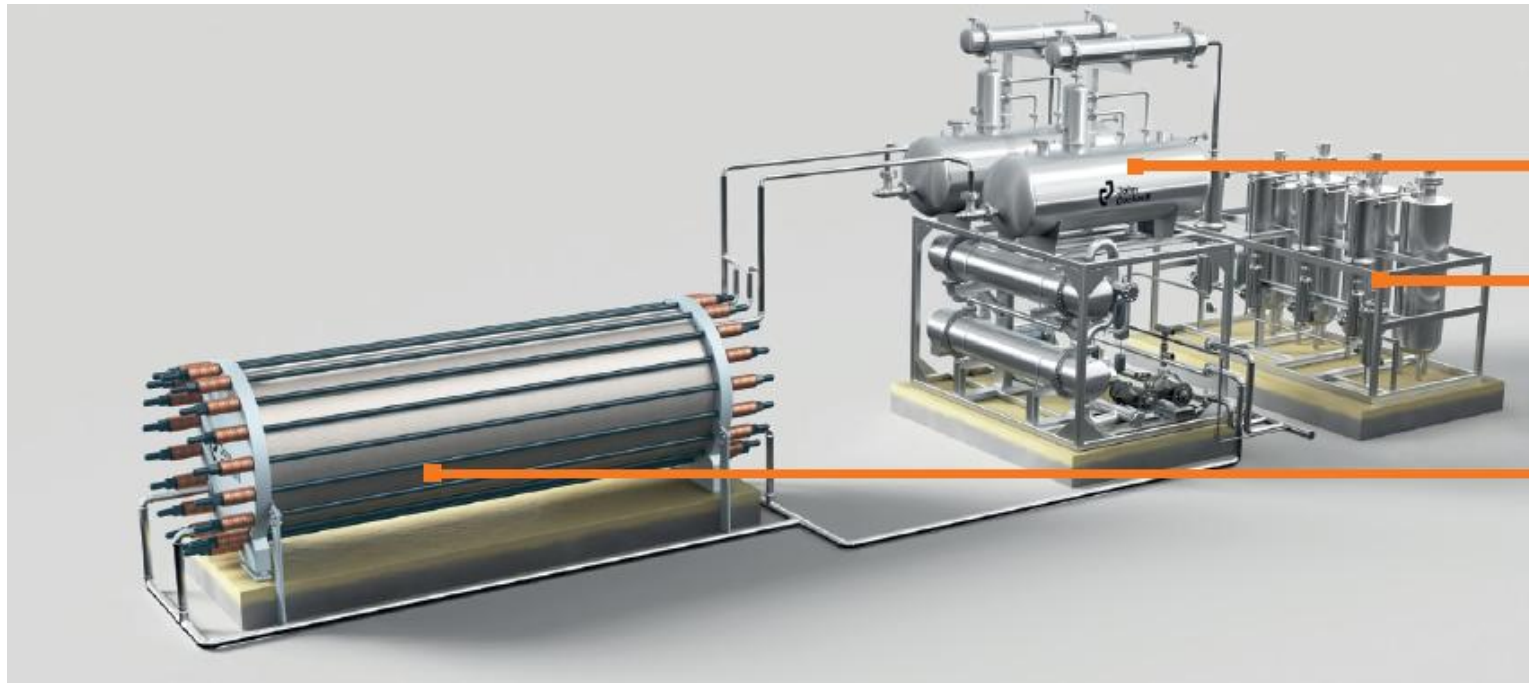

**Gas/Lye Separation**

**Purification**

**Electrolyzer Stack**



# What's inside a « stack » ?

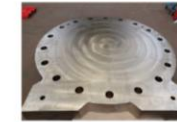
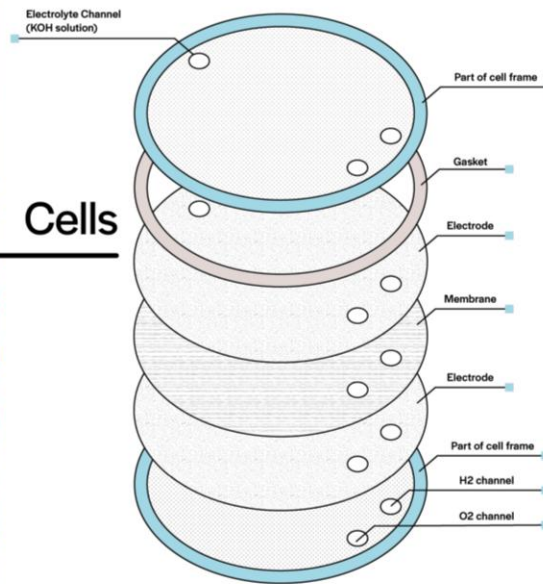

End Plates

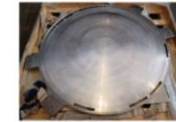

Distribution Plates

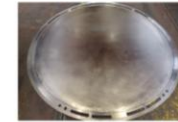

Bipolar Plates

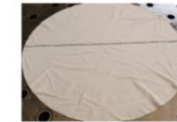

Membranes

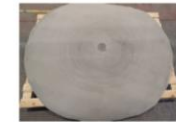

Electrodes



Spacers

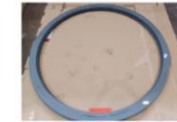

Full & Ring Gaskets



Nuts



Washers



Tie Rods



Isolation Washer & Tubes

# Numerous cells in one stack



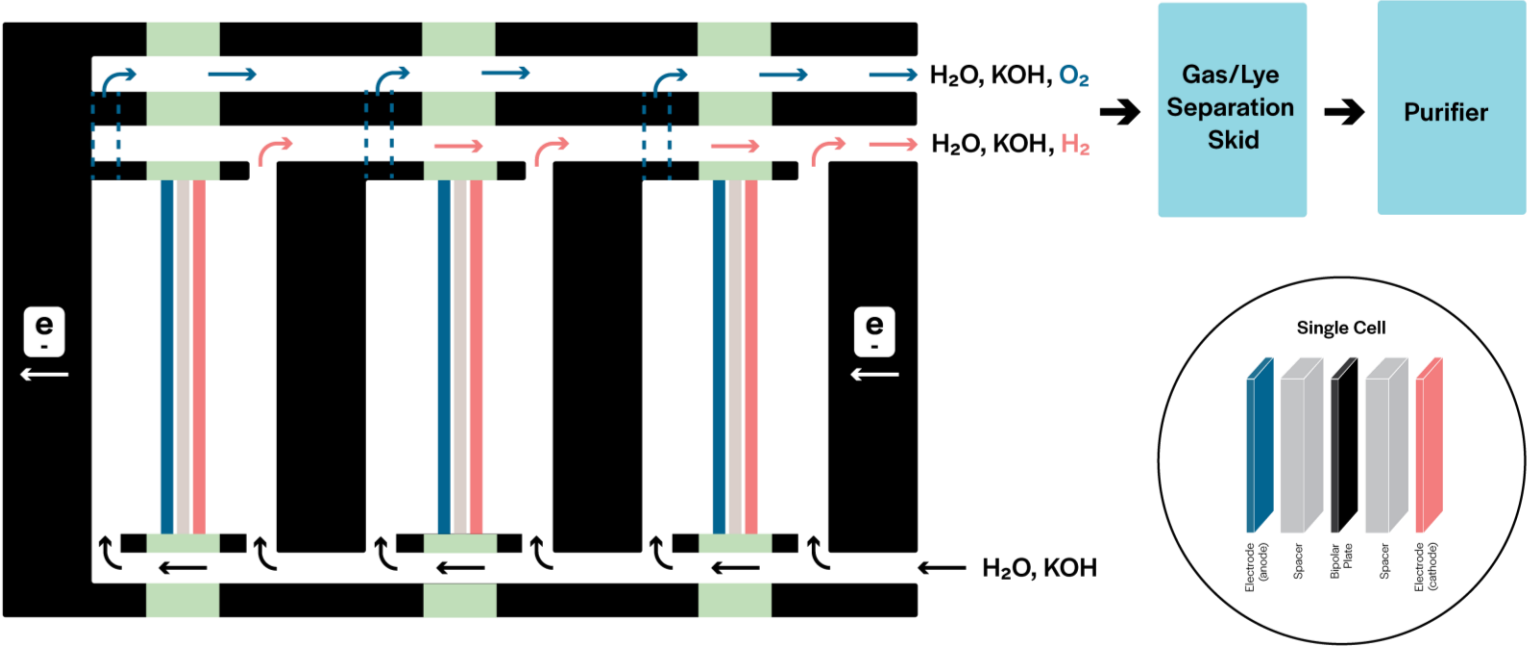

- Bipolar plate
- Spacer
- Membrane
- Electrode (cathode)
- Electrode (anode)
- Seals



Example of a stack with 3 cells



# John Cockerill ongoing R&D initiatives

R&D Tracks	Initiatives	Followed KPIs
<b>1</b> Reduce Capex and scale-up 	<b>At stack level:</b> <ul style="list-style-type: none"> <li>Increase current density</li> <li>Reduce use of critical raw materials</li> <li>Standardize and simplify design (less parts)</li> </ul>	<b>At system level:</b> <ul style="list-style-type: none"> <li>Standardize and simplify design</li> <li>N-to-1 modular design (mutualization of PCU, separation and purification units)</li> <li>Optimize output pressure</li> </ul>
<b>2</b> Increase efficiency 	<b>At stack level:</b> <ul style="list-style-type: none"> <li>Decrease cell voltage</li> <li>Minimize stray currents</li> <li>Enhance cell design</li> <li>Increase operating pressure</li> </ul>	<b>At system level:</b> <ul style="list-style-type: none"> <li>Optimize process &amp; control laws</li> <li>Communalize auxiliaries</li> <li>Use high efficiency components</li> </ul>
<b>3</b> Enhance durability 	<ul style="list-style-type: none"> <li>Refine understanding and modelling of mechanisms at hand (steady-state operation, poisoning, cycling)</li> <li>Develop representative accelerated stress tests</li> <li>Perform tests up to industrial scale</li> <li>Define and implement mitigation strategies</li> </ul>	
<b>4</b> Optimize the design for intermittent operation 	<ul style="list-style-type: none"> <li>Improve operability (minimum turndown, ramp rate, start time)</li> <li>Work on differential pressure control</li> <li>Develop digital twin of electrolyzer</li> <li>Adapt system topology for optimized exploitation of renewable sources</li> </ul>	
<b>5</b> Increase stack size 	<ul style="list-style-type: none"> <li>Design larger single stack units</li> </ul>	

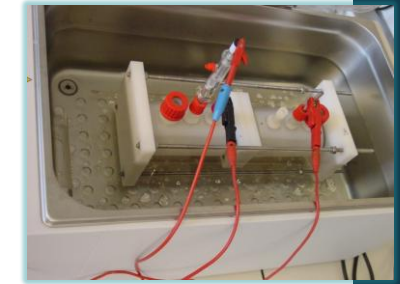

# Green H2: massive investments in a booming electrolyzer market

Announced clean hydrogen investments through 2030 have grown eightfold since 2020 (including \$110 billion investments in committed projects)

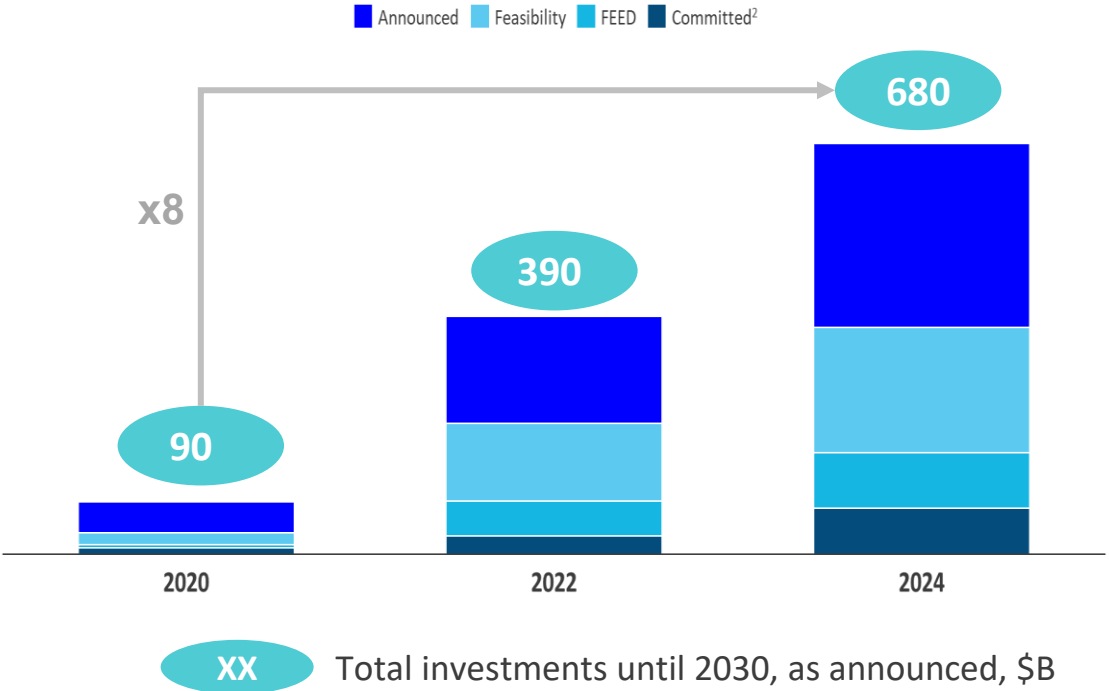

These investments are pushing the demand for electrolyzers to levels never seen before

Forecast cumulative electrolyzer capacity by region

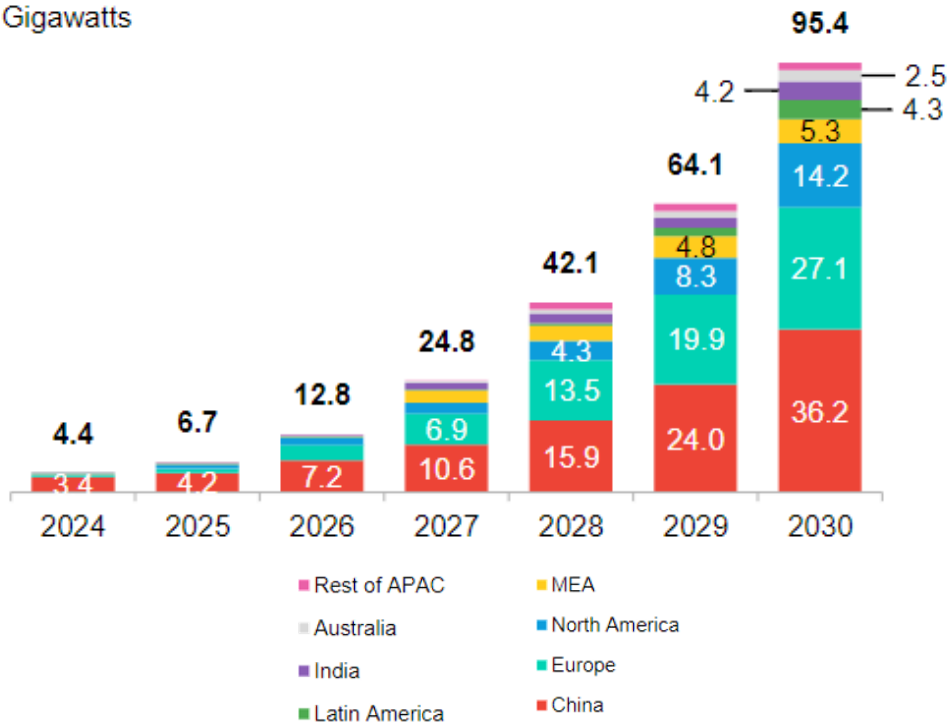

Sources: Hydrogen Council & McKinsey, BloombergNEF

# The solution to decarbonize hard-to-abate sectors

- Green hydrogen is of **strategic importance** for **energy transition and energy sovereignty**
- Green hydrogen is a **key enabler of decarbonization for hard to abate sectors** such as shipping, aviation, chemicals & steel
- 2 major market segments are readily addressable and present a substantial opportunity
  - i. Replacing grey hydrogen in existing processes (e.g. oil refining)
  - ii. Feedstock for hard to abate industries (e.g. green steel, e-methanol, e-SAF, etc.)



# Green H2 can decarbonize “hard-to-abate” industries

Replacement of **GREY** by **GREEN** hydrogen is the priority use of green H2

Non-exhaustive view

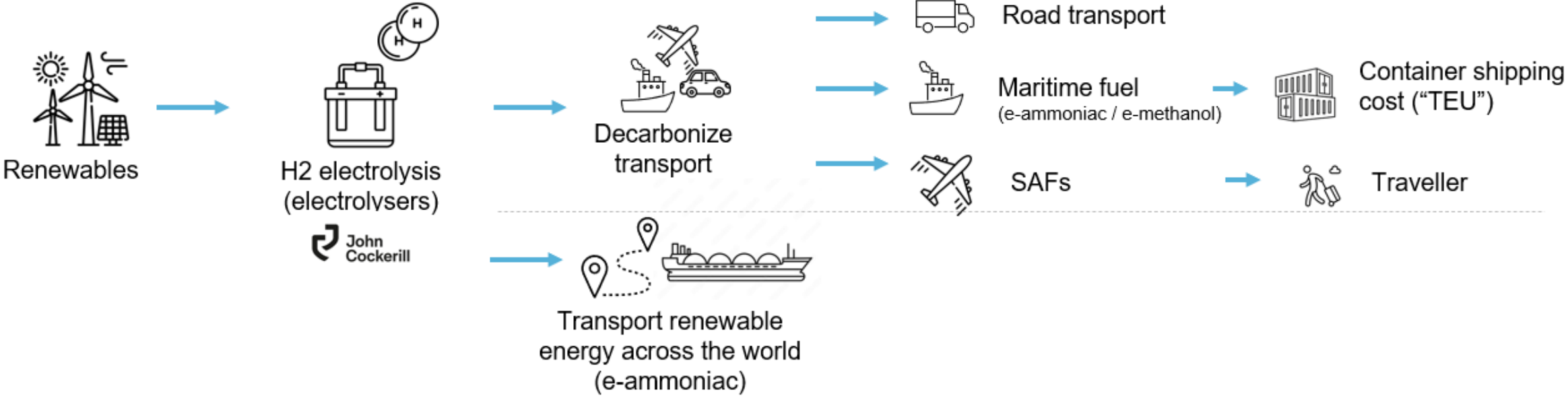

➔ Green H2 deployment requires developing in parallel each segment of the value chain

# Green hydrogen can be converted into other « e-molecules »

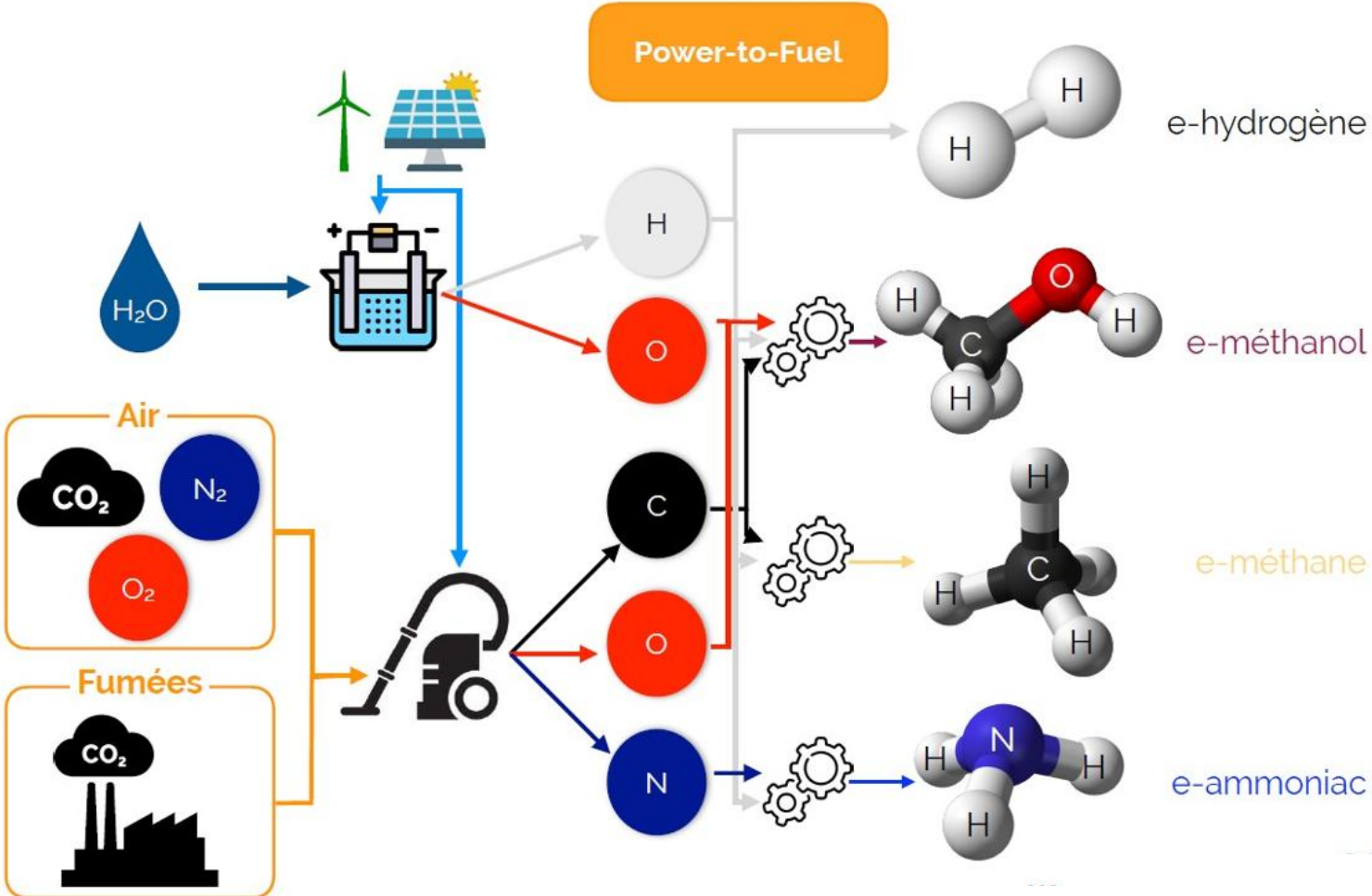

# « Rome was not built in a day » ...

Time required to scale from 1 GW to 100 GW for different technologies

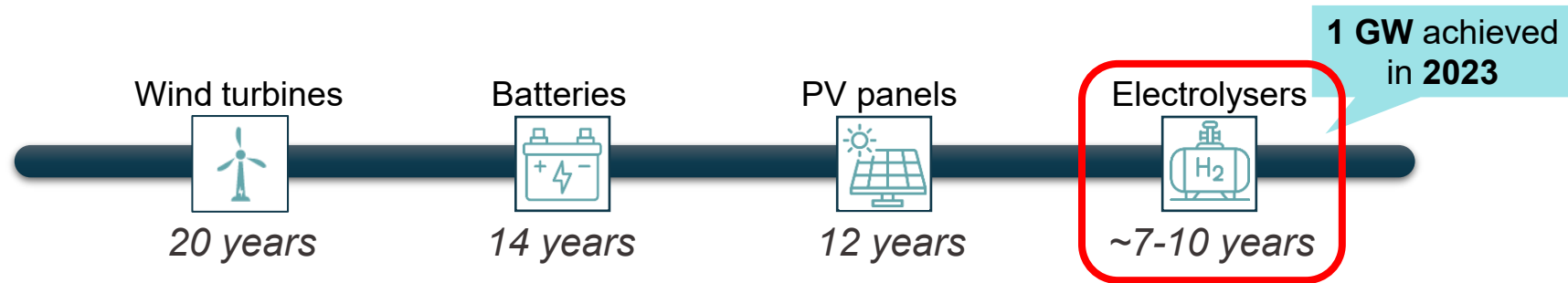

Clean hydrogen sector presented a remarkable growth since 2020

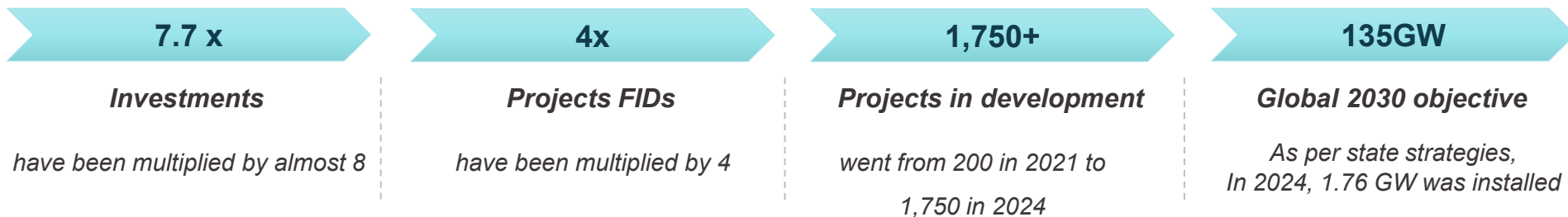

# Examples of real John Cockerill projects

## ▪ Sinopec Kuqa refinery (China)

- 120 MW (24 stacks of 5 MW)
- In operation since 2023
- Green hydrogen supplying a Sinopec refinery



## ▪ HyOffWind (Belgium)

- 25 MW
- In construction
- Mobility, industrial demand, injection gasnat network & grid balancing



## ▪ H2 Metz (France)

- 2,5 MW + Hydrogen refueling station
- In construction
- Mobility : busses & garbage trucks



## ▪ Kakinada (India)

- 1300 MW (1 MM ton/year NH3)
- Tranche 1 (640MW) in construction
- Green ammonia export



# Can electrolyzers follow the intermittency of power supply ?

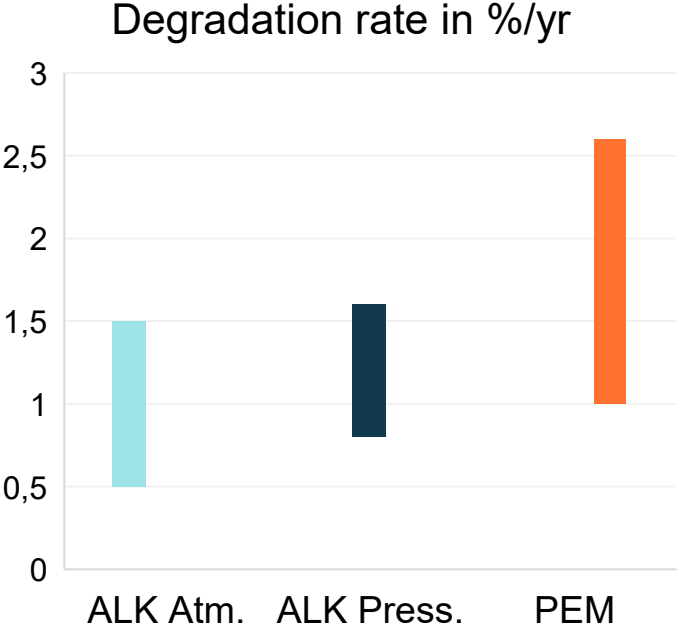
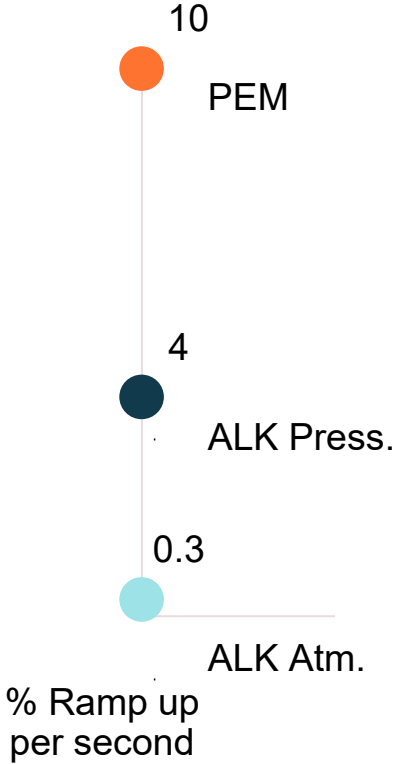
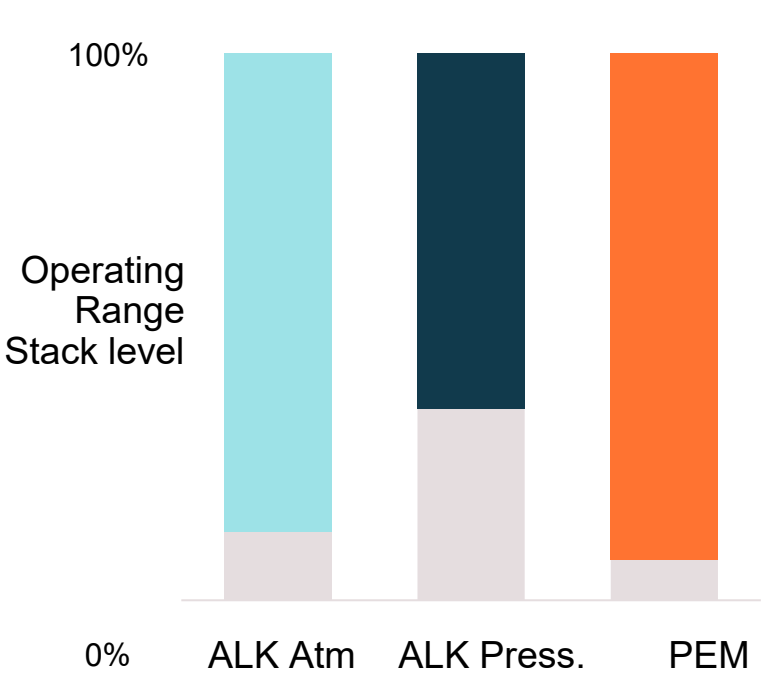

# Can electrolyzers follow the intermittency of power supply ?



**5 X 5MW electrolyzers at 40% = 10MW**  
 Plant of 25MW is at 40%

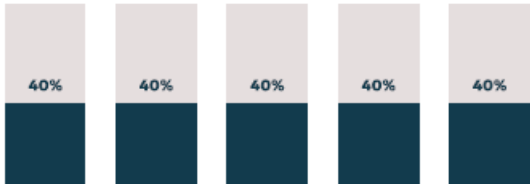

**1 X 5MW electrolyzers at 40% = 2MW**  
 Plant of 25MW is at 8% -> requirement is met

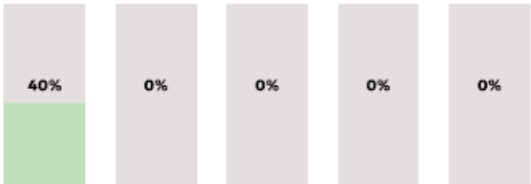

Figure B: Comparing stack level versus plant level approach to reaching production output needs.

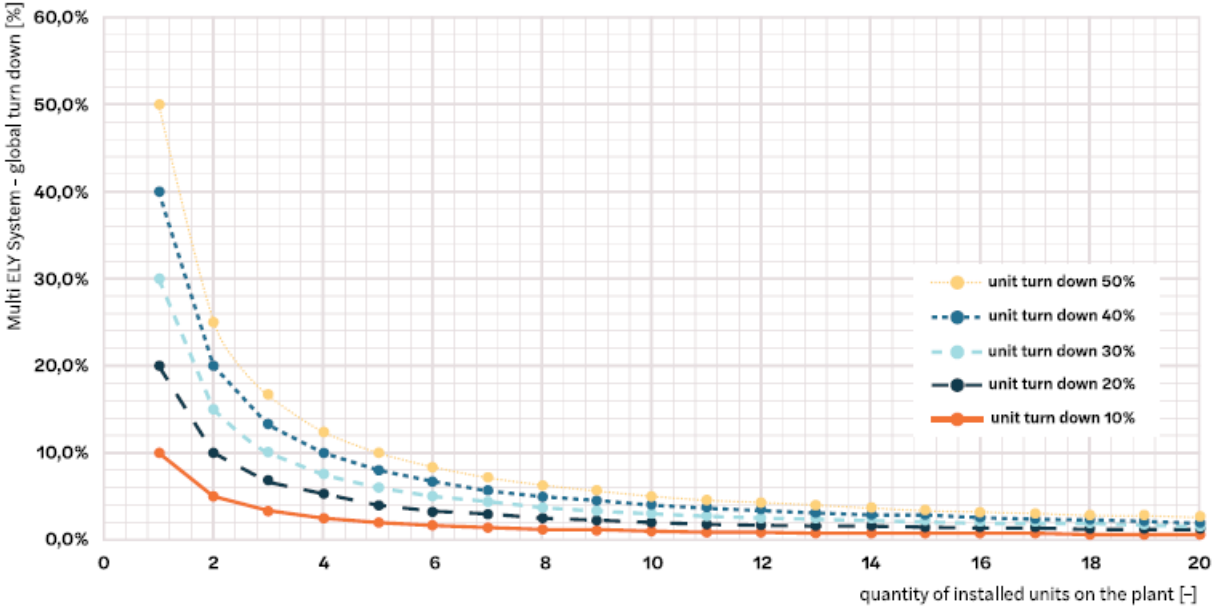
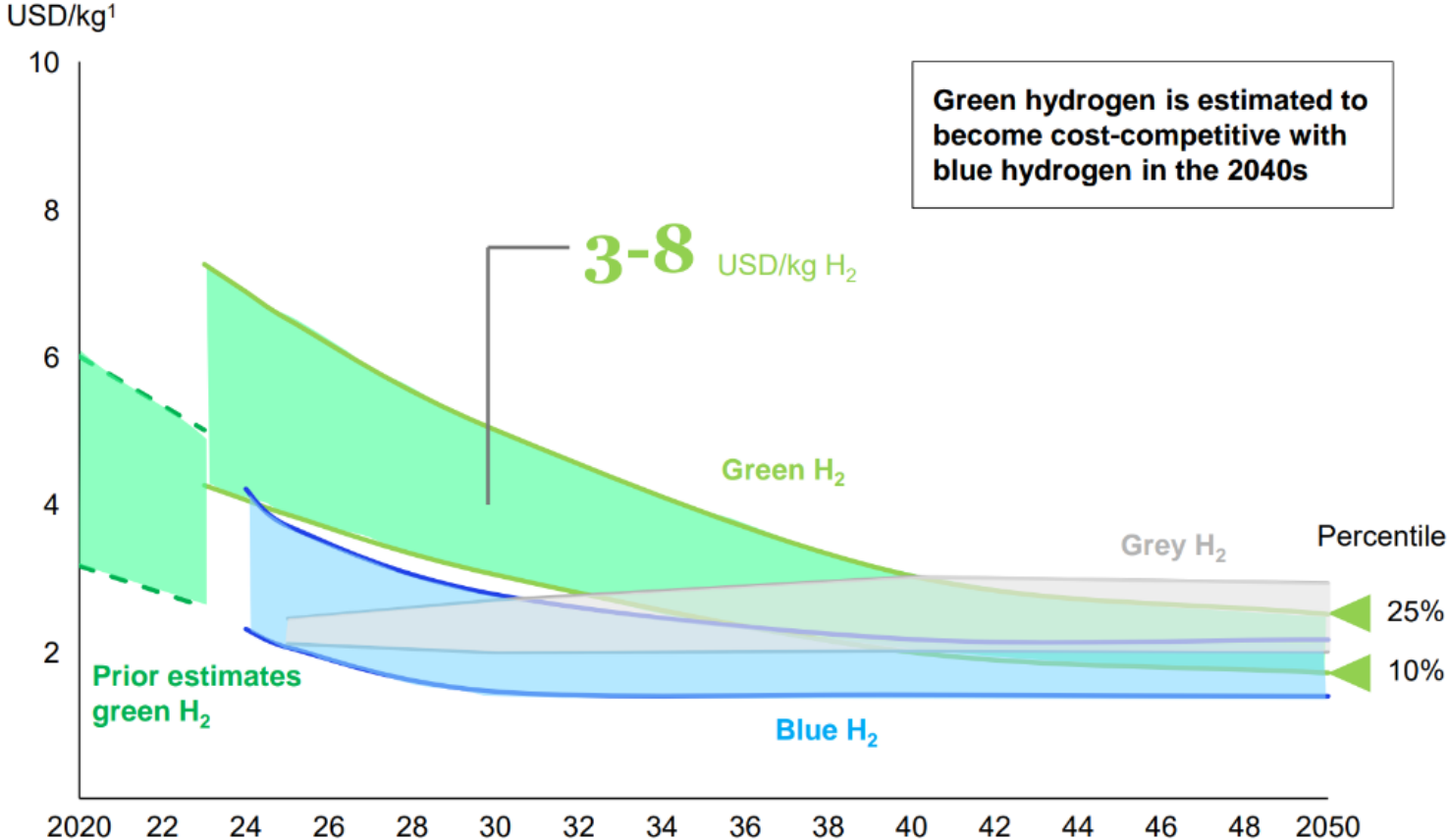

Figure C: Comparing the number of stacks used against the turndown percentage of an individual stack shows that the turndown percentage matters less and less as more electrolyzers are added to the plant.



# Is it competitive ? Green vs. blue vs. grey

*Levelised cost of hydrogen in most attractive regions (top 10%)*



# Can we afford green hydrogen to decarbonize ?

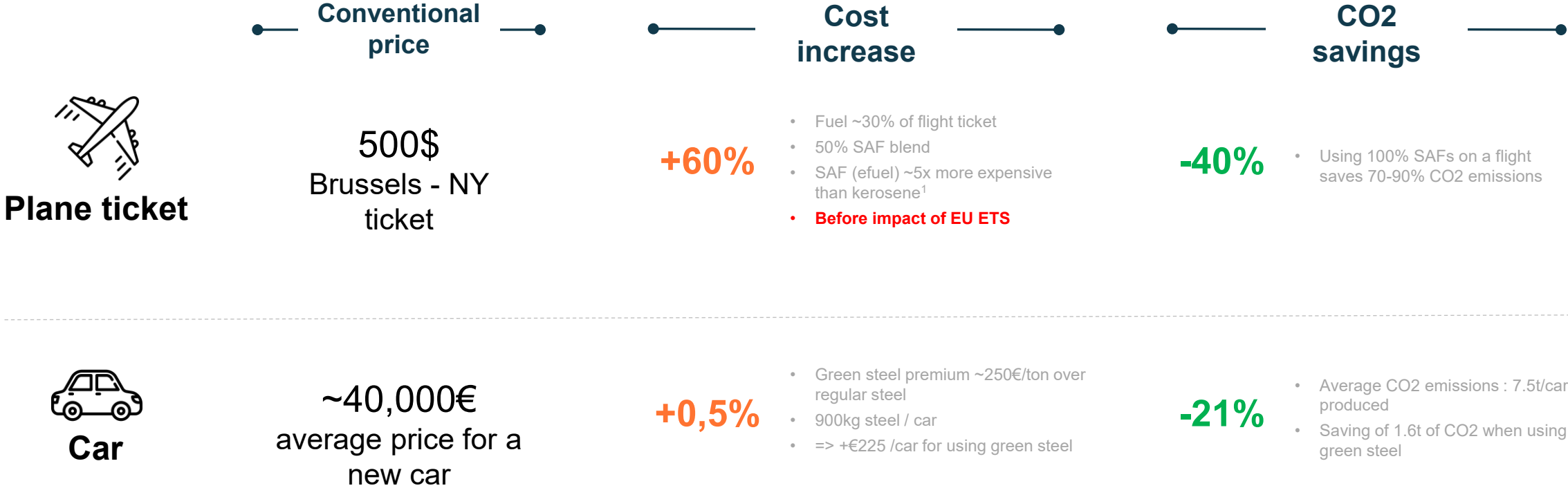

(1) IEA report from December 2023 ("The Role of E-fuels in Decarbonising Transport")

# Belgium: a rich eco-system



# John Cockerill geographical expansion



## Gigafactory in operations

### > Europe

Seraing, Belgium  
Aspach, France

### > Chine

Suzhou



## Gigafactory in construction

### > USA

### > India



## Gigafactory in development

### > Middle-East

### > Morocco

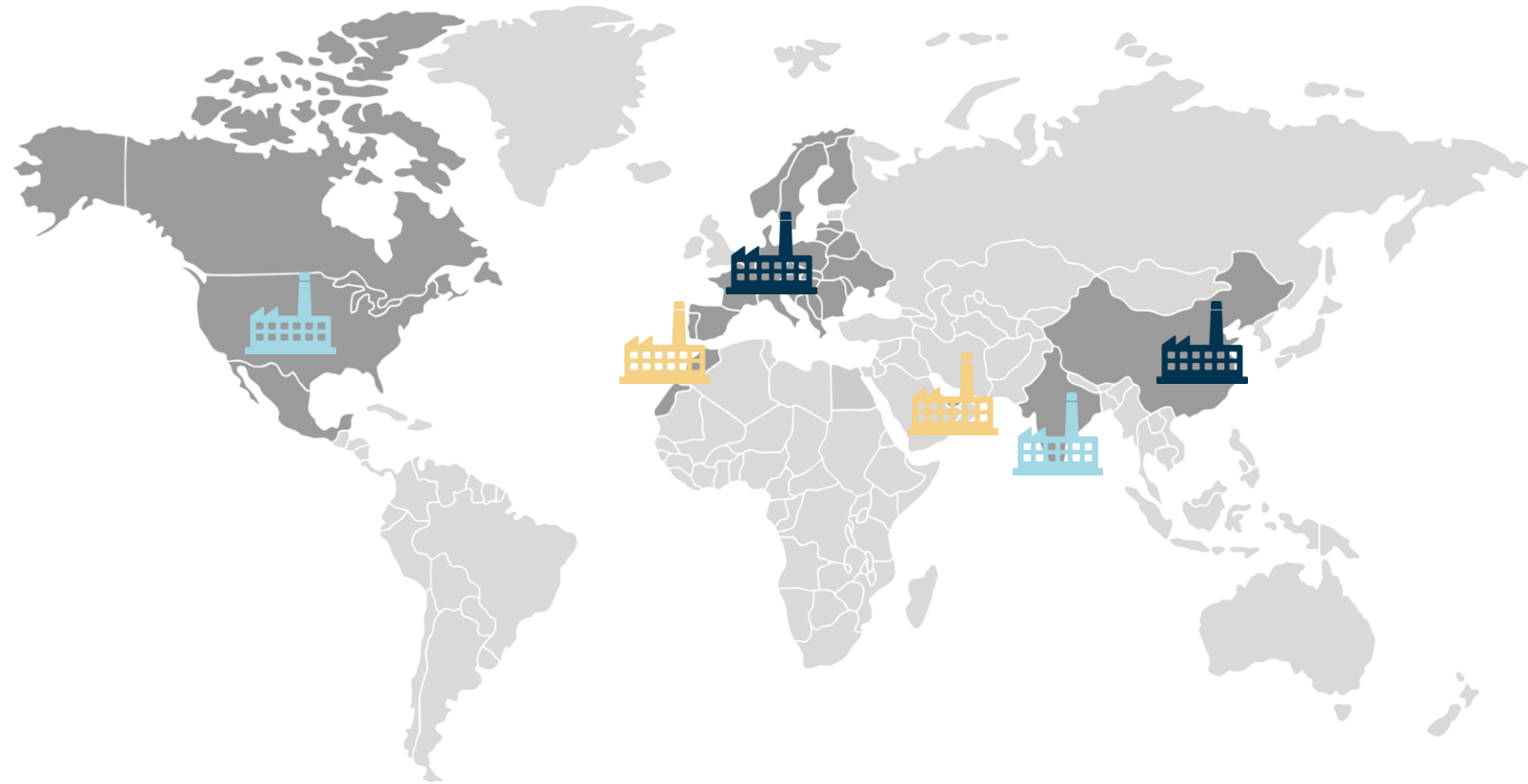

# Thank you

## John Cockerill Hydrogen

Rue Jean Potier 1  
4100 Seraing  
Belgium

[hydrogen@johncockerill.com](mailto:hydrogen@johncockerill.com)

[hydrogen.johncockerill.com](http://hydrogen.johncockerill.com)

## Raphael TILOT

[raphael.tilot@johncockerill.com](mailto:raphael.tilot@johncockerill.com)

T. +32 475 30 28 40

